



General Certificate of Secondary Education
November 2024

Centre Number

--	--	--	--	--

Candidate Number

--	--	--	--	--

Mathematics

Unit M6 Paper 2
(With calculator)
Foundation Tier



[GMC62]

GMC62

THURSDAY 21 NOVEMBER, 10.45am–11.45am

TIME

1 hour.

INSTRUCTIONS TO CANDIDATES

Write your Centre Number and Candidate Number in the spaces provided at the top of this page.

You must answer the questions in the spaces provided.

Do not write outside the boxed area on each page, on blank pages or tracing paper.

Complete in black ink only. **Do not write with a gel pen.**

Questions which require drawing or sketching should be completed using an HB pencil. All working **must** be clearly shown in the spaces provided. Marks may be awarded for partially correct solutions.

You **may** use a calculator for this paper.

Answer **all sixteen** questions.

INFORMATION FOR CANDIDATES

The total mark for this paper is 50.

Figures in brackets printed down the right-hand side of pages indicate the marks awarded to each question or part question.

You should have a calculator, ruler, compasses and a protractor.

The Formula Sheet is on page 2.

14868



20GMC6201

Formula Sheet

$$\text{Area of trapezium} = \frac{1}{2}(a + b)h$$



$$\text{Volume of prism} = \text{area of cross section} \times \text{length}$$

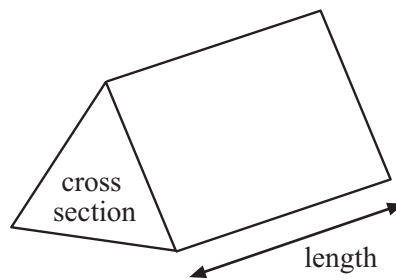

1

1 inch is 2.54 cm

Will the fridge fit into the space in the kitchen cabinet shown?

fridge

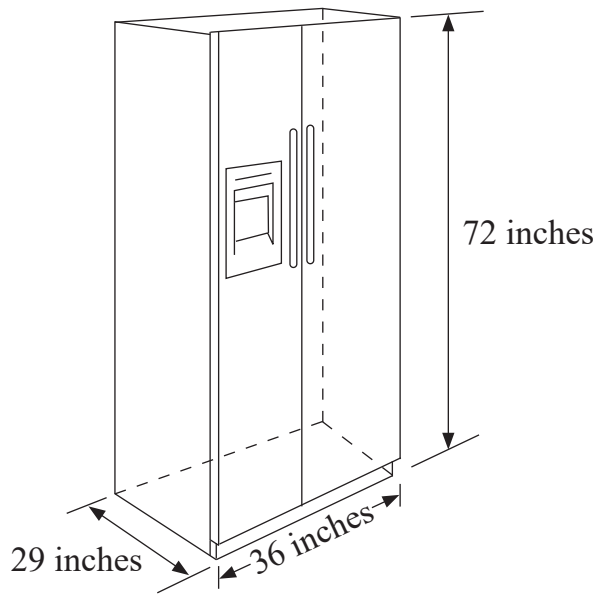

space in kitchen cabinet

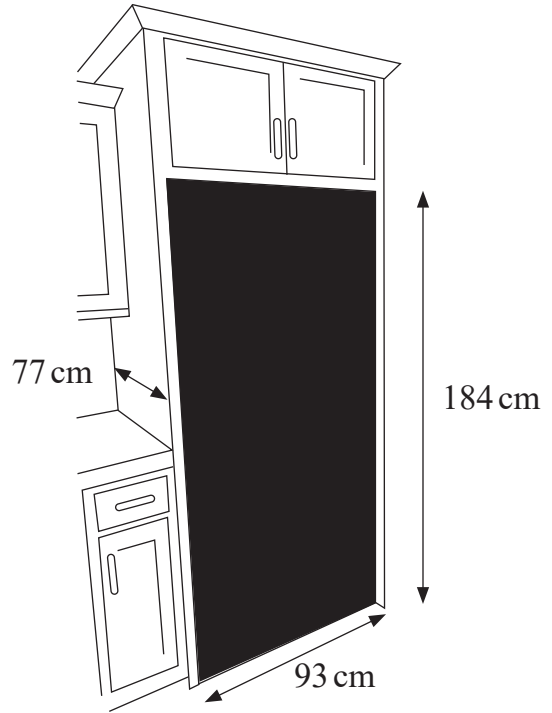

You must show all of your working out.

Answer _____ [3]

[Turn over



2 (a)

Centigrade (°C)	-10	0	10	20
Fahrenheit (°F)	14	32	50	68

Use the table to draw a conversion graph to change between Centigrade (°C) and Fahrenheit (°F). [3]

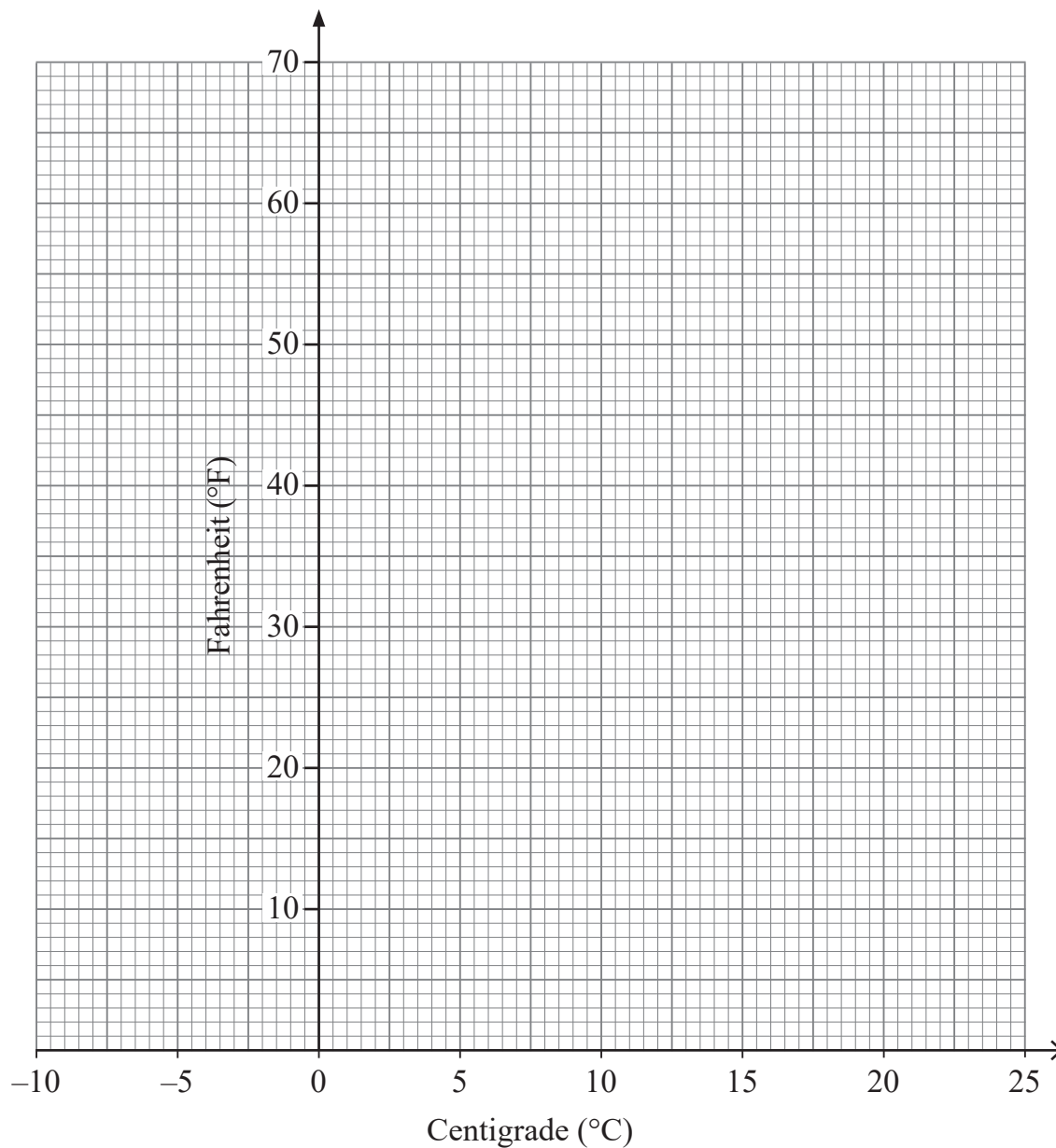

(b) Use the graph to change 57°F to °C

Answer _____ °C [1]



3 The rule to find the next number in a sequence is

Multiply by 3 and then add 1

The **second** term of a sequence is 13

(a) Use the rule to find the **third** term in this sequence.

Answer _____ [1]

(b) Use the rule to find the **first** term in this sequence.

Answer _____ [2]



4 A canteen has four options for breakfast.

The table shows the probability for each option.

Option	Probability
Toast	0.35
Cereal	0.15
Scone	0.3
Croissant	0.2

Use the table to fill in the blanks.

(a) _____ is the least popular option. [1]

(b) _____ is twice as popular as _____ . [1]



5 The diagram shows the position of two ships P and Q and a lighthouse L.

The scale is 1 cm represents 20 km.

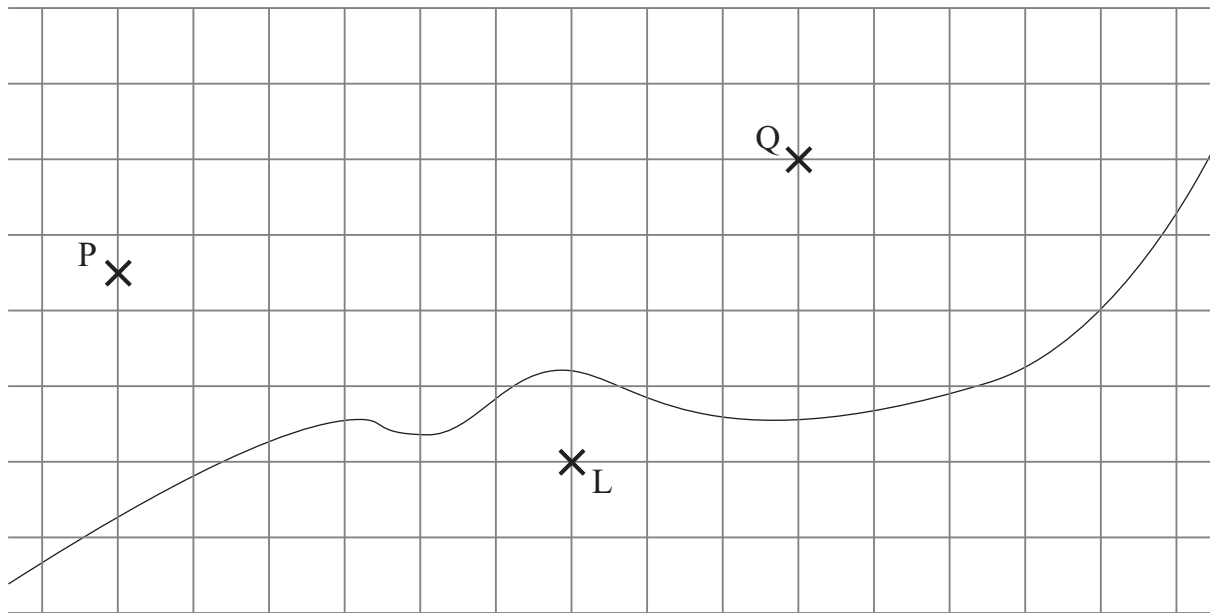

Which ship is closer to L and how much closer is it?

Show your working out clearly.

Answer _____ is closer by _____ km [3]

[Turn over



6

diagrams not
drawn accurately

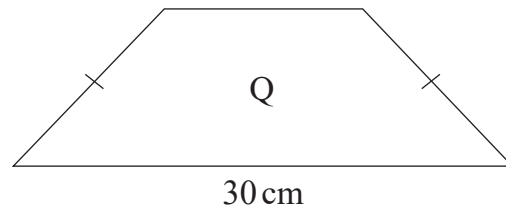
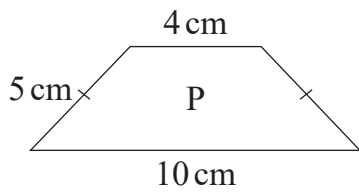

Shape P is enlarged to give shape Q.

Work out the perimeter of shape Q.

Answer _____ cm [3]



7 Dylan wants to calculate his car's fuel consumption.

(a) He travels 180 miles and uses 24 litres.

Calculate his car's number of miles per litre.

Answer _____ miles per litre [1]

He wants to work out the number of miles per gallon.

1 gallon = 4.54 litres

(b) Calculate his car's number of miles per gallon.

Answer _____ miles per gallon [2]

[Turn over



8 Izzy's uncle sent her **four** 200 rand banknotes for her birthday.

$$£1 = 20.806 \text{ rand}$$

(a) Izzy **estimates** in her head how much she will get for her four notes.

How much does she estimate?

Show your working out clearly.

Answer £ _____ [1]

(b) How much **less** does Izzy get when the exact exchange rate is used?

Show your working out clearly.

Answer £ _____ [2]



9 Work out the size of angle x in the hexagon.

diagram not
drawn accurately

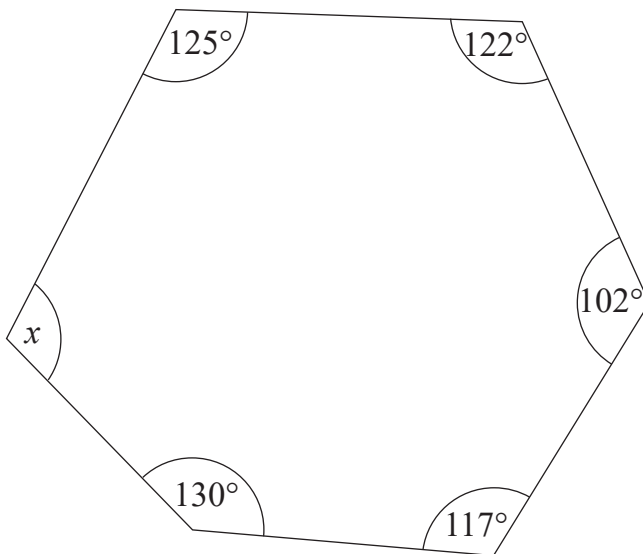

Answer $x =$ _____ ° [4]

[Turn over



10 A spinner is spun once.

It lands on A, B, C or D.

The probability of it landing on C and D is shown in the table.

The probability of it landing on A is the same as the probability of it landing on B.

Landing on	A	B	C	D
Probability			$\frac{1}{2}$	$\frac{3}{10}$

Work out the missing probabilities for A and B.

Write your answers in the table.

[3]



11 Jill has ten 50 pence coins and eight 20 pence coins.

Jack also has 50 pence coins and 20 pence coins.

Jack has the same total number of coins as Jill, but his coins are worth £2.10 less.

How many 20 pence coins does Jack have?

Answer _____ 20 pence coins [3]

[Turn over

14868



20GMC6213

12 The ingredients to make eight biscuits are:

Flour 160 g

Sugar 50 g

Butter 100 g

Pauline has 700 g of flour, 150 g of sugar and 520 g of butter.

How many grams of butter has she **left over** if she makes the **largest** number of biscuits she can?

Answer _____ g [4]



13 There are 55 girls and 20 boys in Year 13

The probability that a girl in Year 13 has a part-time job is $\frac{2}{5}$

The probability that a boy in Year 13 has a part-time job is $\frac{3}{4}$

Work out the probability that a student in Year 13 has a part-time job.

Answer _____ [4]

[Turn over



14 Rotate the triangle 180° about the point $(3,1)$

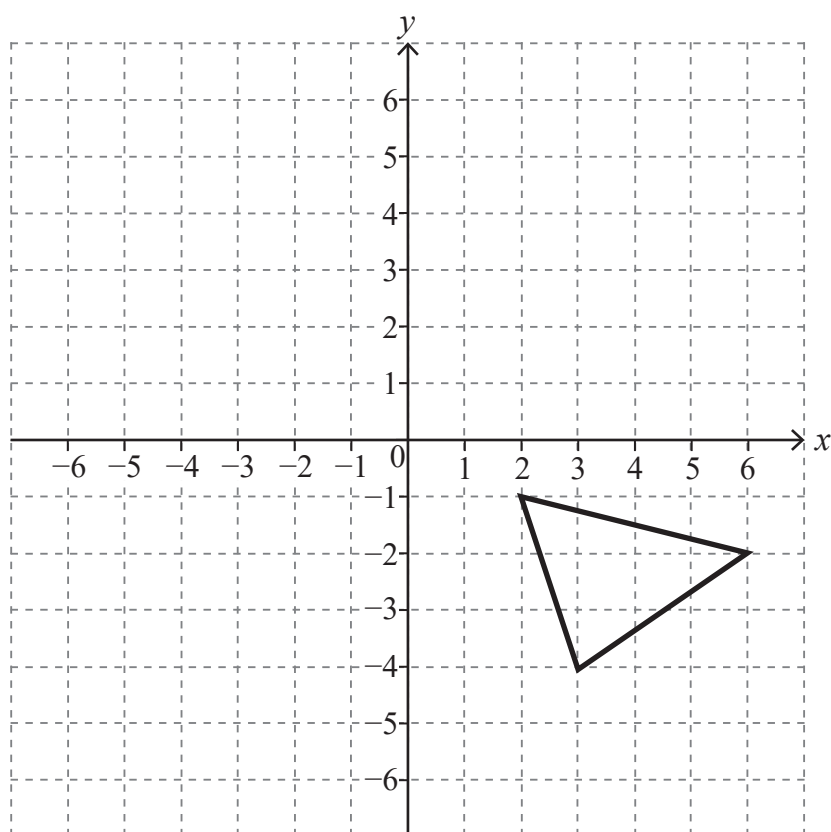

[2]



16 Solve the inequality

$$-5 < 2n \leq 8$$

showing all possible **integer** values for n on the number line below.

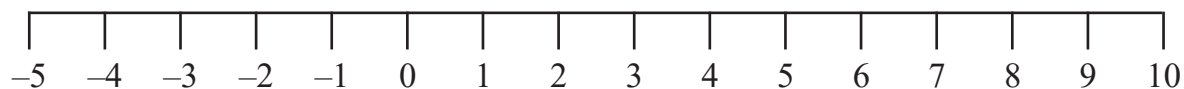

[2]

THIS IS THE END OF THE QUESTION PAPER





BLANK PAGE
DO NOT WRITE ON THIS PAGE

14868



20GMC6219

Sources: All images © CCEA unless stated

DO NOT WRITE ON THIS PAGE

For Examiner's use only	
Question Number	Marks
1	
2	
3	
4	
5	
6	
7	
8	
9	
10	
11	
12	
13	
14	
15	
16	

Total Marks	
--------------------	--

Examiner Number

Permission to reproduce all copyright material has been applied for.
In some cases, efforts to contact copyright holders may have been unsuccessful and CCEA will be happy to rectify any omissions of acknowledgement in future if notified.

